



Principal characteristics

- The PMA-12 transducer, a development of the PME series, is designed for installation with self-aligning joints.
- The IP67 protection level makes the PMA-12 highly suitable for humid and wet environments and in temporary immersion (CEI EN 60529).
- Available only with cable output.
- Ideal for applications on metalworking and ceramics machines, as well as on earth-moving machines and utility vehicles. Recommended in all cases where the angle of the drive axle changes constantly.

TECHNICAL DATA

Useful electrical stroke (C.E.U.)	50 to 1000mm
Independent linearity (within C.E.U.)	see table
Resolution	Infinite
Repeatability	≤ 0,08 mm
Hysteresis	≤ 0,25mm
Electrical connection	PMA12 F 3-pole shielded cable 1m
Protection level	IP67 (CEI EN 60529)
Life	> 25x10 ⁶ m strokes, or > 100x10 ⁶ operations, whichever is less
Displacement speed	≤ 5 m/s
Max. acceleration	≤ 10m/s ² displacement
Shock test DIN IEC68T2-27	50g, 11 ms single stroke
Vibrations DIN IEC68T2-6	12g, 10...2000Hz
Cursor dragging force	≤ 0.5 N
Displacement sensitivity (no hysteresis)	da 0.05 a 0.1 mm
Tracking error	See table
Tolerance on resistance	±20%
Recommended cursor current	< 0,1 μA
Maximum cursor current in case of bad performances	10mA
Maximum applicable voltage	See table
Electrical isolation	>100MΩ at 500V~, 1bar, 2s
Dielectric strength	< 100μA at 500V~, 50Hz, 2s, 1bar
Dissipation at 40°C (0W at 120°C)	See table
Thermal coefficient of resistance	-200 +200 ppm/°C typical
Actual Temperature Coefficient of the output voltage	≤ 5 ppm/°C typical
Working temperature	-30...+100°C
Storage temperature	-50...+120°C
Material for transducer case	Anodised aluminium, PSU
Material for cursor magnets	POM
Mounting	Self-aligning joints with adjustable distance between centres

MECHANICAL DIMENSIONS

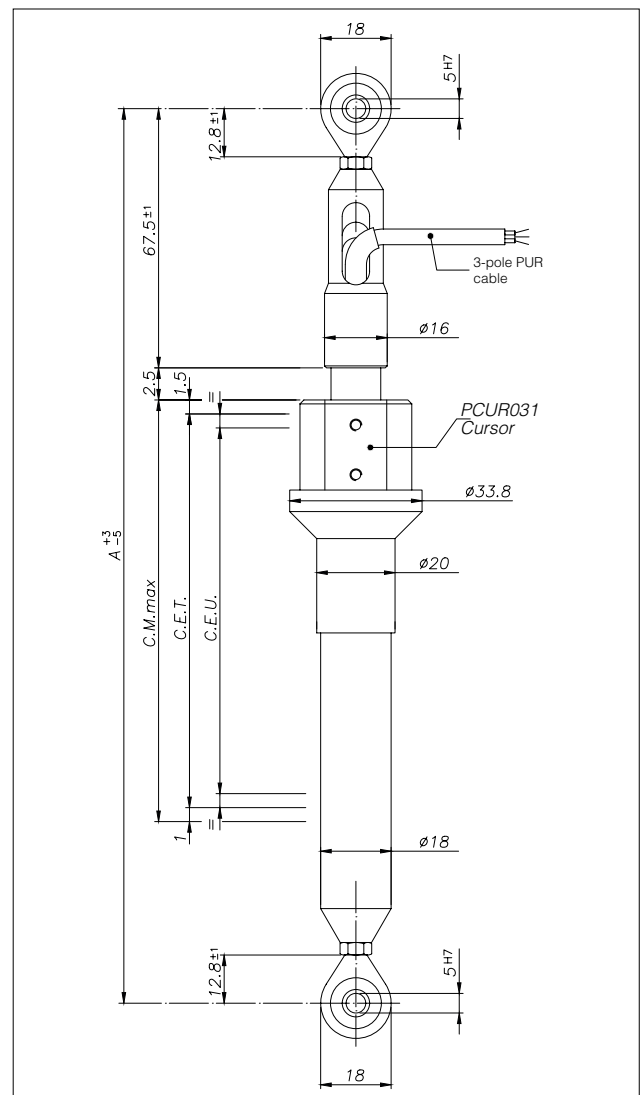

Important: all data shown in the catalog for linearity values and temperature coefficients are valid when the sensor is used as voltage divider with maximum current of $I_c < 0.1 \mu A$ in the circuit.

ELECTRICAL / MECHANICAL DATA

MODEL		50	100	150	200	250	300	350	400	450	500	550	600	650	700	750	800	850	900	950	1000
Useful electrical stroke (U.E.S.) +1 / -0	mm	Model																			
Theoretical electrical stroke (T.E.S.) ± 1	mm	U.E.S. + 1																			
Resistance (on T.E.S.)	kΩ	5					10					20									
Independent linearity (within U.E.S.)	±%	0,1					0,05														
Dissipation at 40°C (0W at 120°C)	W	1	2	3																	
Max. applicable voltage	V	40		60																	
Mechanical stroke MC	mm	U.E.S. + 3,5																			
Case length (A)	mm	U.E.S. + 155																			

CURSOR PCUR031

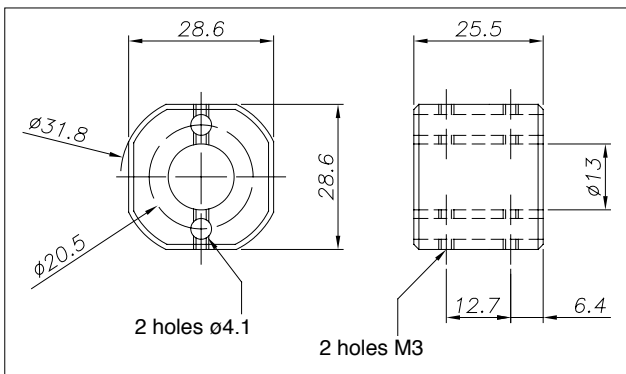

TRACKING ERROR

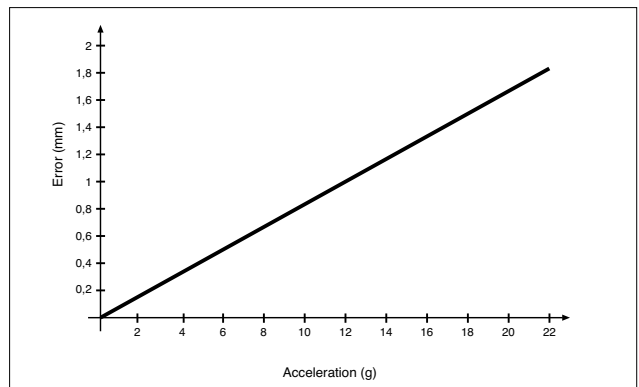

ELECTRICAL CONNECTIONS

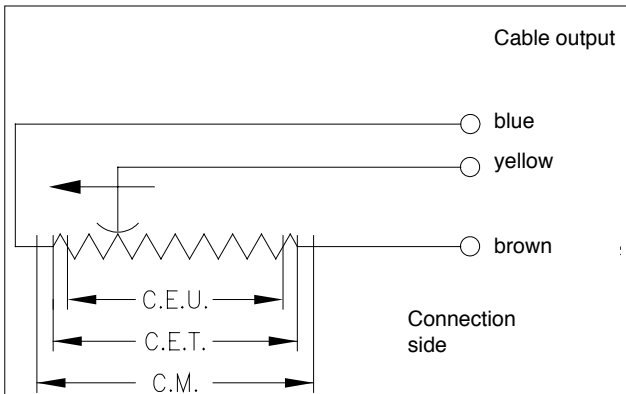

INSTALLATION INSTRUCTIONS

- Respect the indicated electrical connections (DO NOT use the transducer as a variable resistance)
- When calibrating the transducer, be careful to set the stroke so that the output does not drop below 1% or rise beyond 99% of the supply voltage.

ORDER CODE

Position transducer **PMA**

Dimensions 1/2"

PUR 3 pole cable output 3x0,25 1m

Model

Empty

Mechanical and/or electrical characteristics differing from those in the standard version may be arranged on request.

Ex.: **PMA-12-F-400-X 0000-X000-XX-00-XXX**

Position transducer model PMA12, stroke 400

CODE EXTENSION

CABLE LENGTH (version F standard 1mt)
 Output F 00 =1mt 02 =2mt 03 =3mt 04 =4mt 05 =5mt
 10 =10mt 15 =15mt

GEFRAN spa reserved the right to make aesthetic or functional changes at any time and without notice.